



Made in America

Full Time Continuous Monitor Operation, Installation and Maintenance



Figure 1. EMIT Full Time Continuous Monitor

Description

Leading companies use continuous monitors as a cost effective component in satisfying the paragraph 6.1.3 Compliance Verification Plan requirements of ANSI/ESD S20.20. The EMIT Full Time Continuous Monitor provides 100% monitoring of both the operator and the work surface. This unit provides continuous monitoring of:

- One user wearing a wrist strap
- ESD worksurface
- Ground (50514 only)

Note: Worksurface must have a conductive layer such as Dual Layer Rubber, Dissipative 3-Layer Vinyl or Micastat® Dissipative Laminate with conductive buried layers. EMIT Continuous Monitors are not recommended for use with homogeneous matting.

If the unit detects that the elements are outside industry standards, the continuous monitor will alarm by both an audible signal and an illuminated red LED to notify the user of a problem.

Unlike many units, the Full Time Continuous Monitor (50514 only) also continuously verifies ground (AC outlet ground). When the Power Cord is plugged in, a self-test runs automatically. If the AC outlet is wired incorrectly, both red LEDs will illuminate and the audible alarm will sound. The unit has an additional wrist strap ground point banana jack for a second user or supervisor.

The Full Time Continuous Monitor is available in two models:

Model	Description	Voltage
50514	Full Time Cont. Monitor	120 VAC
50519	Full Time Cont. Monitor	220 VAC

ADVANTAGES OF WORKSTATION CONTINUOUS MONITORING OVER PERIODIC TESTING

Many customers are eliminating periodic testing and are utilizing workstation continuous monitoring to better ensure that their products were manufactured in an ESD controlled environment. Full time workstation continuous monitoring is superior to pulsed monitoring as well as periodic testing, and can save a significant amount of money in testing costs and rejected products. Periodic testing detects failures after ESD susceptible products have been manufactured. The costs of dealing with the resulting catastrophic or latent defects can be considerable. Full Time Continuous Monitors eliminate the need for users to test wrist straps and log the results; by their function, these monitors satisfy the ISO 9000 and ANSI/ESD S20.20 Paragraph 6.2.2.2. test logging requirements. Per ESD-S1.1 paragraph 6.1.3 Frequency of Functional Testing "Daily (Wrist Strap) testing may be omitted if constant monitoring is used."

Per ESD Handbook TR 20.20 paragraph 5.3.2.4.4 Test Frequency "Because wrist straps have a finite life, it is important to develop a test frequency that will guarantee integrity of the system. Typical test programs recommend that wrist straps that are used daily should be tested daily. However, if the products that are being produced are of such value that knowledge of a continuous, reliable ground is needed, and then continuous monitoring should be considered or even required."

WAVE DISTORTION DETECTION TECHNOLOGY PROVIDES TRUE 100% CONTINUOUS MONITORING

EMIT utilizes wave distortion technology for the Full Time Continuous Monitor, which is an Impedance type monitor.

Per ESD TR12-01 section 2.2 Impedance (or single wire) constant monitors "The capacitance type of monitor is also known as an impedance monitor. They both work on the same theory, however the impedance monitor uses a detection circuit designed to reduce false alarms and eliminate adjustments. 'Single Wire' or 'impedance type' monitors use the phase difference between current and voltage to detect changes in impedance of the cord, band and person. A very low AC voltage is used for constant sensing. Any standard wristband and coiled cord can be used."

Thus the wave distortion circuitry monitors current/voltage phase shifts and provides true 100% continuous monitoring. Electrical current will lead voltage at various points due to the combinations of resistance and capacitive reactance. By monitoring these "distortions" or phase shifts, the wave distortion Full Time Continuous Monitor will reliably determine if the circuit is complete.

Wave distortion technology can be referred to as “vector impedance monitoring”. This description is valid as the wave distortion technology measures the impedance at the monitored banana jack and looks for changes in either the capacitance or resistance of the circuit which includes the wrist strap and its wearer. It uses filtering and time domain sampling to filter out false signals caused by voltage offsets, 60 Hz fields and other electro-magnetic and electrostatic interference.

In normal factory environments, and with persons whose capacitance with respect to ground is within design limits (5 feet tall 90 pound person to 6 foot 5 inch 250 pound person), the Full Time Continuous Monitor cannot be “fooled”. It will provide a reliable alarm only when the wrist strap or work surface becomes dysfunctional or unsafe according to accepted industry standards. The Full Time Continuous Monitor is drift-free and designed to be insensitive to the effects of squeezing or stretching the coil cord.

ADVANTAGES OF WAVE DISTORTION AND SINGLE-WIRE TECHNOLOGY

The EMIT Full Time Continuous Monitor allows the use of any standard, single-wire wrist strap and coil cord. The monitor / wrist strap / cord system life-cycle costs are by far lower than alternative systems which require dual-wire cords and special wrist straps. Dual-wire cords are expensive and are the weak link of the system, the most likely component to need replacement. Over a five year period, this can make the dual-wire system three to five times as expensive as a system utilizing single-wire wrist straps and cords. See Calibration section on page 4 to minimize life cycle costs.

The dictionary defines constant as uniform and unchanging, and continuous as uninterrupted. Nonetheless, some dual-wire resistance monitors utilize a pulsed test current and do not really provide continuous monitoring. For example, during each 2.2 second pulse cycle of a leading “constant” resistive monitor, electrical current is pulsed for only 0.2 seconds followed by an unmonitored interval of 2 seconds. This leaves the user/wrist strap unmonitored for over 90% of each cycle. Damaging static charges can easily occur in the portion of the time in between the pulses. The off period of 2 seconds equals 2 billion nanoseconds, and “it takes only about 25 volts applied for 100 nanoseconds to blow most memories or microprocessors”.* Some dual-wire systems do not reliably meet all industry specifications, as the cords may not meet the EOS/ESD S-1.0 paragraph 4.1.6 one to five pound “breakaway force” requirement for operator safety.

By using the reliable wave distortion technology to determine if the circuit is complete, there are no false alarms. There is no need to adjust or tune the monitor to a specific user or installation. The miniscule amount of electrical current (less than 1 volt coil cord signal) required to generate the waveform has never caused reported skin irritation and is extremely safe for use in voltage sensitive applications such as disk drive manufacturing.

*1981 article by Donald E. Frank - Electrical Overstress Electronic Discharge Symposium Proceedings

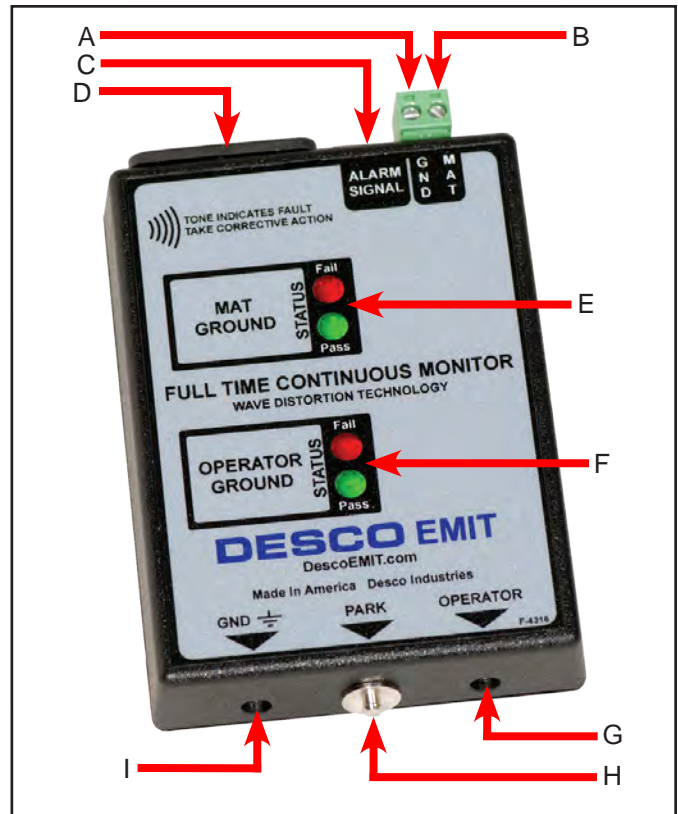

Figure 2. Full Time Continuous Monitor features and components

Features and Components (See Figure 2)

A. Mat Ground: Grounds worksurface mat.

B. Mat Connection: Monitors worksurface mat.

C. I/O Signal Output: Can be used to output to a light tower. (Relay required, see Figure 4)

While facing connector:

Pin 1: is on left, no connection

Pin 2: circuit ground

Pin 3: 24 VDC @ 1mA max

Pin 4: no connection

Pin 5: open collector, 1 mA max

Pin 6: no connection

D. IEC Power Cord Inlet: Connect the power cord here.

E. Mat Ground LEDs: When the green LED is lit, the work surface mat is properly grounded. When the red LED is lit, the work surface mat and/or electrical ground is not properly grounded.

F. Operator Ground LEDs: When the green LED is lit, the operator is properly grounded. When the red LED is lit, the operator is not properly grounded.

G. Monitored Operator Jack: Where the operator inserts the wrist cord banana plug.

H. 4mm Parking Snap: When touched by the operator, this snap will deactivate the alarm for six seconds. This allows time for the operator to disconnect the coil cord from the wrist band and park it on this snap. While parked, the coil cord disables the alarm, allowing the operator to leave the workstation. The OPERATOR GROUND LED will remain off while the cord is parked. Upon returning and removing the coil cord from the parking snap, the operator has six seconds to hook up to the wrist band before the alarm sounds.

I. Auxiliary Ground: Unmonitored wrist strap banana jack ground.

Installation

Remove the Continuous Monitor from the carton and inspect for shipping damage. Confirm that the worksurface is 1×10^7 ohms or less and has a conductive layer such as Dual Layer Rubber or Dissipative 3-Layer Vinyl or Micastat® Dissipative Laminate with conductive buried layers. Each unit should include the following:

- 1 Full Time Continuous Monitor
- 2 Mat Monitor Cords (black and green)
- 2 Push and Clinch Snaps
- 1 Velcro® Set
- 1 09070 Desco Wrist Strap Kit
- 1 Power Cord (50514 only)
- 1 Certificate of Calibration

- I. The Full Time Continuous Monitor may be mounted to a convenient location using the included the Velcro® set. It is normally mounted toward the front edge of a workstation where the LEDs are easily visible. See Figure 3 for installation set-up.
- II. Install the Push and Clinch snaps 12-72 inches apart from each other on the work surface mat. Make sure that they pierce and clinch the bottom side of the mat.
- III. Snap both ground cords to the push and clinch snaps installed to the work surface mat.
- IV. Route the black ground cord to the monitor's green terminal block labeled MAT.
- V. Route the green ground cord to the monitor's green terminal block labeled GND.
- VI. Insert the power cord into the power inlet of the monitor, and connect the other end to a proper voltage source.

Operation

When the Full Time Continuous Monitor is installed to an ESD protective worksurface and grounded via a power cord, the green MAT GROUND LED and red OPERATOR GROUND LED should be illuminated. The monitor takes 6 seconds to activate its alarm circuitry when it is first plugged in.

- Correct wiring of the outlet is confirmed when the monitor is plugged in (50514 only).
- The worksurface resistance is measured between the two snaps installed to the mat worksurface (See Figure 3).

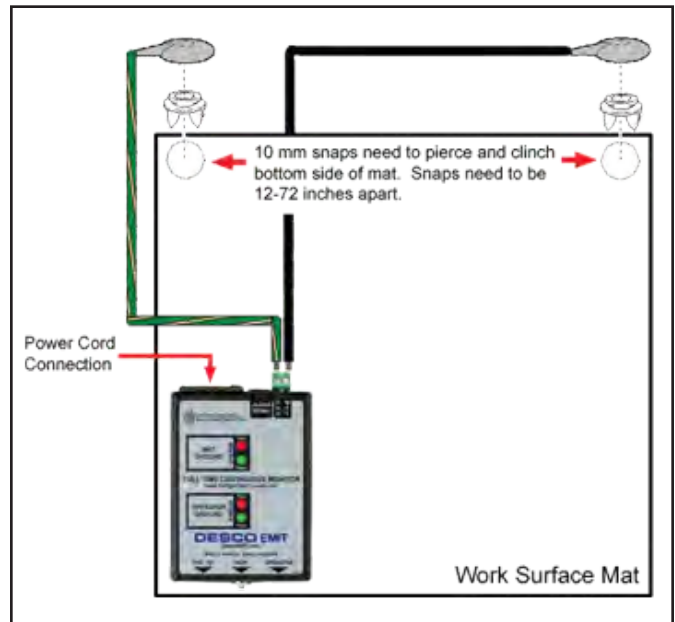

Figure 3. Installation of the Full Time Continuous Monitor

TO USE THE CONTINUOUS MONITOR:

1. Plug a wrist strap cord, not attached to the wristband, into the monitored banana jack labeled OPERATOR on the front of the unit (See Figure 2). This automatically activates the selected operator channel. The red operator LED should illuminate.
2. Remove the charges from your body by making contact with a properly grounded ESD worksurface. Snap the cord to the wristband, and fit it snugly onto your wrist. This should silence the audible alarm and cause the OPERATOR GROUND LED to switch from red to green. If this does not happen, examine the wrist cord for continuity or damage and your wrist band to ensure that it is securely fit. If you have dry skin, apply an approved dissipative hand lotion such as Desco Reztore™ ESD Hand Lotion. When leaving the area, the user can take the wrist cord along or attach it to the monitor parking snap. The audible alarm will shut off in approximately 6-8 seconds when operator wrist cord is removed from unit and will instantly shut off when the cord is attached to the parking snap.

PARKING SNAP

The audible alarm is designed to alert both the operator and supervisor. The parking snap feature allows the operator to disconnect when leaving the work area without sounding the audible alarm. It also provides a means for wrist cord storage (red OPERATOR GROUND LED will illuminate). When the operator touches the parking snap, the audible alarm will disable for 6 seconds. The user can then disconnect the wrist cord from the wrist band and attach it to the parking snap for storage. If the operator removes the wrist cord plug from the OPERATOR banana jack, the audible alarm will sound for 6-8 seconds.

WORK SURFACE CHANNEL

The Full Time Continuous Monitor monitoring circuitry is sufficiently sensitive to detect extremely low current when used with a worksurface with a conductive layer.

Note: The monitor will not detect insulative contamination on the worksurface. Insulative contamination can increase the resistance to ground making the worksurface ineffective." (ESD TR12-01 section 3.1 Worksurface monitors). ESD worksurfaces should be kept clean using an approved ESD cleaner like Reztore™ Antistatic Surface & Mat Cleaner.

When the monitor is connected to an ESD worksurface, the amount of current that flows is a function of the total resistance between the Continuous Monitor and through the worksurface to ground. When the resistance of the worksurface is below a pre-set threshold, the monitor will indicate Pass. Conversely, if the resistance level is high when compared to the monitor's reference, the unit will fail and alarm. This is an integrating resistance measuring circuit, therefore it is relatively insensitive to externally induced electromagnetic fields. The resistance threshold is factory set to 10 megohms. (It can be special ordered to other limits. Contact manufacturer for specifications).

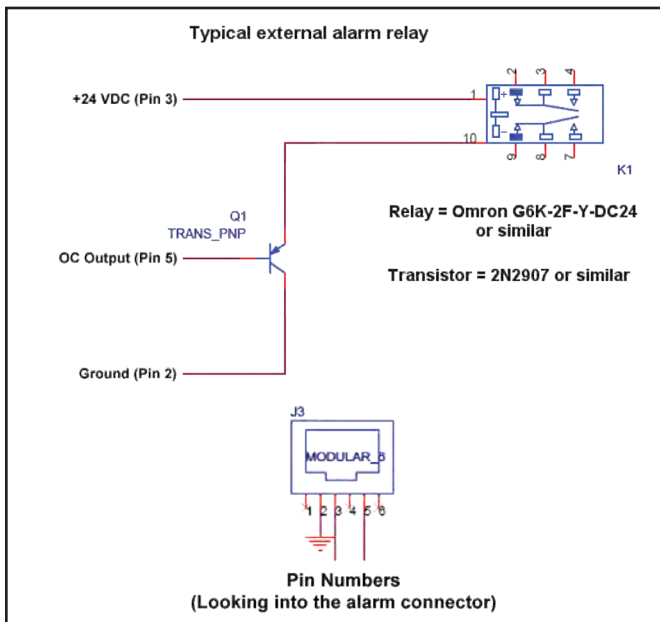

Figure 4. Typical external relay circuit

Specifications

RESISTANCE LIMITS

Test range of monitored circuit	500K - 10M ohms†
Worksurface limit*	Set to 10 megohms
Power Source	50514: 120 VAC
	50519: 220 VAC
	50-60 Hz
Current Drain	<15 mA RMS
Wrist strap open circuit voltage	1.2 volts peak to peak @ 1-2 MicroAmps

Mat test open circuit voltage	5 to 7.5 volts
Response time to alarm	<50 mS
Standby "parking" snap delay	6-8 seconds
Long Term Drift	1/2% per decade (1st decade is 1 hr)
Temperature	10-40 degrees C
Field Adjustment	None required
Size	3/4" x 3-1/4" x 4-3/8"

† This cannot be verified with standard DC test equipment. The continuous monitor is an impedance sensing device and the limits are determined by the magnitude and angle of the impedance.

* Contact factory for special limits.

Maintenance and Calibration

The Full Time Continuous Monitor is solid state and designed to be maintenance free. The 50514 / 50519 is calibrated to standards traceable to NIST. There are no user adjustments that can be made. Because of the impedance sensing nature of the test circuit, special equipment is required for calibration. We recommend that calibration be performed annually, using the EMIT 50512 Continuous Monitor Calibration Unit. The Calibration Unit is a most important product which allows the customer to perform NIST traceable calibration on continuous monitors. The 50512 is designed to be used on the shop floor at the workstation, virtually eliminating downtime, verifying that the continuous monitor is operating within tolerances.

Limited Warranty

EMIT expressly warrants that for a period of five (5) years from the date of purchase EMIT Continuous Monitors will be free of defects in material (parts) and workmanship (labor). Within the warranty period, a credit for purchase of replacement EMIT Continuous Monitors, or, at EMIT's option, the Continuous Monitor will be repaired or replaced free of charge. If product credit is issued, the amount will be calculated by multiplying the unused portion of the expected five year life times the original unit purchase price. Call our Customer Service Department at 909-664-9980 for a Return Material Authorization (RMA) and proper shipping instructions and address. Please include a copy of your original packing slip, invoice, or other proof of date of purchase. Any unit under warranty should be shipped prepaid to the EMIT factory. Warranty replacements will take approximately two weeks.

If your unit is out of warranty, call our Customer Service Department at 909-664-9980 for a Return Material Authorization (RMA) and proper shipping instructions and address. EMIT will quote repair charges necessary to bring your unit up to factory standards.

Warranty Exclusions

THE FOREGOING EXPRESS WARRANTY IS MADE IN LIEU OF ALL OTHER PRODUCT WARRANTIES, EXPRESSED AND IMPLIED, INCLUDING MERCHANTABILITY AND FITNESS FOR A PARTICULAR PURPOSE WHICH ARE SPECIFICALLY DISCLAIMED. The express warranty will not apply to defects or damage due to accidents, neglect, misuse, alterations, operator error, or failure to properly maintain, clean or repair products.

Limit of Liability

In no event will EMIT or any seller be responsible or liable for any injury, loss or damage, direct or consequential, arising out of the use of or the inability to use the product. Before using, users shall determine the suitability of the product for their intended use, and users assume all risk and liability whatsoever in connection therewith.